



Énergie NB Power

The Smith Residence:

A Solar Powered Net Zero Home

Purpose

Ever increasingly, New Brunswick homeowners are excited by and engaged in the idea of producing some or all, of their home's energy needs. Renewable energy sources such as wind and solar are being explored as options become more accessible. More and more New Brunswickers are talking about renewables. It is exciting for New Brunswickers to be able to lessen their energy footprint, by making their homes more energy efficient and by generating energy onsite.

Though they may generate their own electricity and meet most of their energy needs, the majority of these homes and businesses are still connected to 'the grid' – the province's electricity distribution system. Staying connected to the grid ensures an uninterrupted supply of energy, even when the demands of the home or business exceed the on-site supply. It also means that whichever renewable energy system is installed can be sized to meet the average daily usage, rather than the peak demand.

This case study considers the Smith residence in Sackville, New Brunswick. The Smith home uses solar power as its renewable energy source and produces as much energy as it uses from the solar panels, on a yearly basis, making it a net zero home. Although it is net zero, it is still net metered with NB Power for the times when the panels don't produce enough energy to meet current demand. Alternatively, credits accumulate for the homeowners when a surplus of power is generated and put back on the grid.

Building

Blane and Heather Smith had a vision when they sought out a location to build near Sackville, NB back in 1988. The vision was one of a sun-filled home that would have a very small energy footprint. To realize this dream, they chose a house plan with many east and south facing windows in order to passively heat the home. The Smiths installed high levels of insulation throughout their home and made it air-tight by carefully considering all the construction details to make sure the home would have very low air leakage rates. They also chose a central heating system that gave them the option to convert to various technologies fairly easily. For additional comfort and ambiance, the Smiths also included a woodstove.

Fast forward to 2012, and an energy efficiency program for Net Zero homes was offered through Efficiency NB (note: Efficiency NB is now operating through NB Power Energy Efficiency Services). The Smiths decided to participate in the Net Zero program and as a result installed an air source heat pump, solar hot water, a drain water heat recovery system, R-40 insulation in the ceiling and solar panels to offset electricity consumption. Thanks to the careful attention to detail and energy efficiency in the construction of the home, the Smiths pre-upgrade EnerGuide rating was not bad at 78. But the upgrades resulted in an impressive post-upgrade assessment rating of 90. Orienting their home for sun-filled rooms also paid off as that decision served to make the home 'solar ready.' It was well positioned to add solar panels and generate energy onsite.

The Smiths were smart to think of the whole home, and to carry out energy efficient upgrades to their home. It lowered their baseline energy usage, making it easier for their solar panel system to meet their home's energy demands in the run of an average day, and by choosing to net-meter with NB Power, they could size the solar system to meet their average daily usage, rather than a peak energy usage day.

Technologies

With the Smith's home built "solar ready," choosing to install solar panels as the renewable energy source for their home was an easy decision. "We were also familiar with the technology, and comfortable with the maintenance level," says Heather.

The Smiths decided to install a solar panel array, consisting of 24 Solar World SW235 Mono V2.0 panels, combining for a total of 5.6 kilowatts of capacity. The solar panels the Smith family used, The Sunmodule Plus[®] 235-watt module, has a guarantee that the power performance will not decrease by more than 0.7% per year over a 25-year period. The panels can also sustain loads of up to 113 pounds per square foot. Although the panels are built to be very durable, harsh conditions can reduce their power performance. A façade that blocks wind and snow but allows UV light to pass would significantly lengthen the lifespan of these panels.



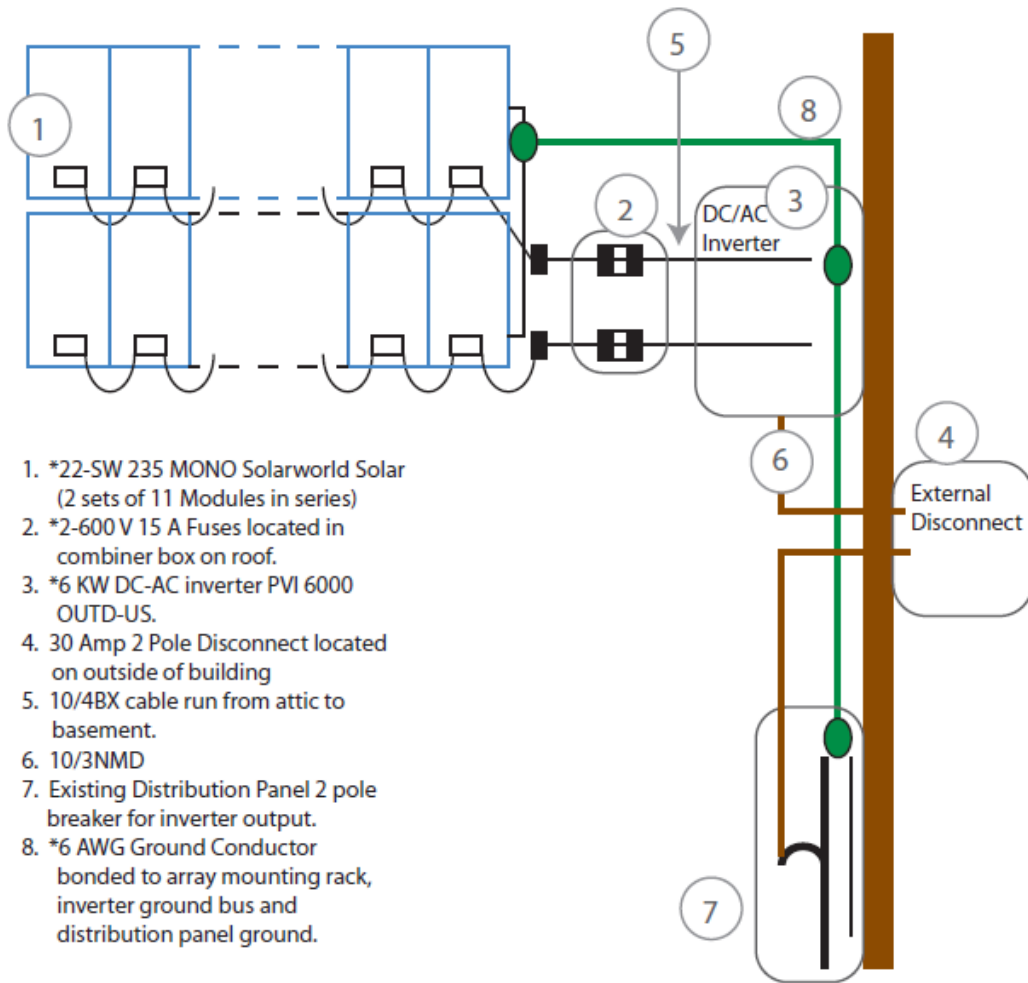

Along with the solar panels, the Smiths achieved energy efficiency from the use of triple glazed windows.

Energy Production

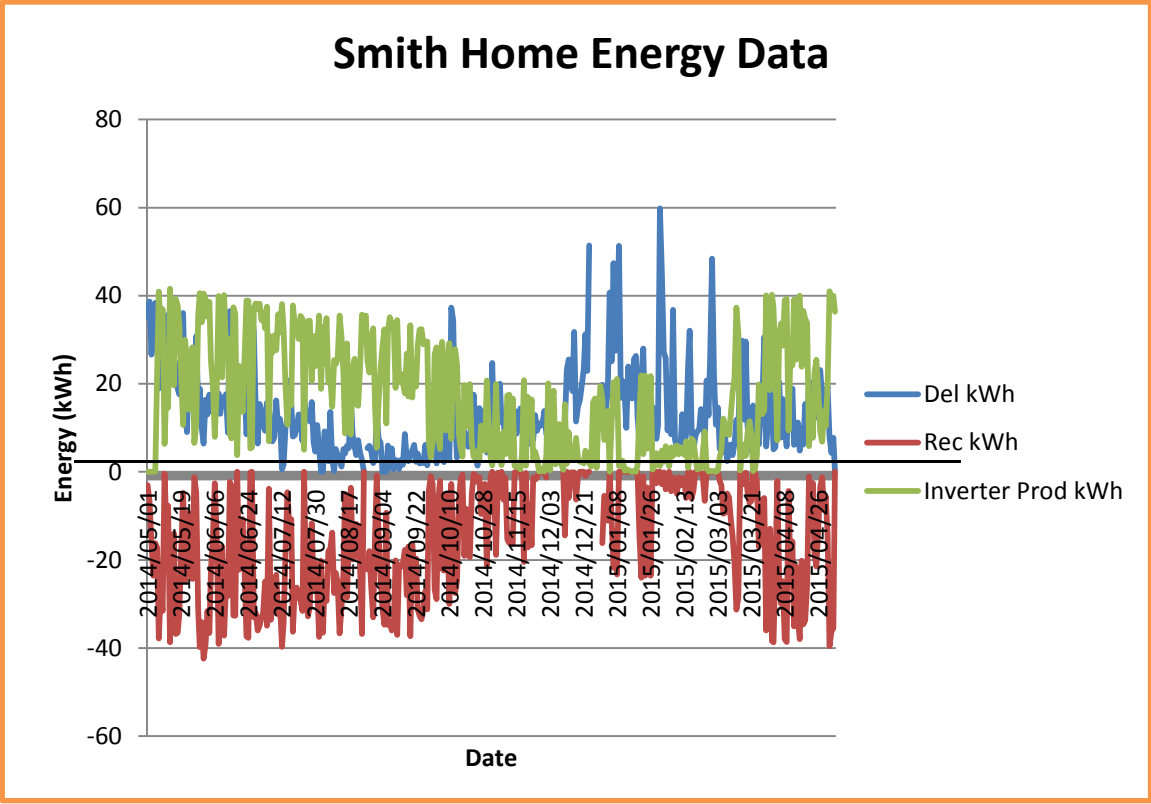

Figure 1: The total energy delivered and received by the grid and the amount of energy the inverter produced in one year.

Table 1: The monthly and daily averages of the energy being produced by the inverter, how much money it saved and the credit the Smiths received from NB Power.

Month	Monthly consumption (kWh) *	Average Daily Production (kWh) **	Monthly Production (kWh) ***	Savings (\$) ****	Credit Received (kWh) *****
January	758	6.8	211.6	21.69	-189.3
February	530	3.7	103.8	10.65	-55.2
March	417	11.5	358.1	36.71	-270.6
April	418	24.9	749.8	76.85	-626.6
May	382	28.0	869.4	89.12	-656.4
June	310	26.5	795.6	81.55	-695.8
July	485	28.4	882.5	90.46	-777
August	282	24.5	762.0	78.11	-652
September	192	23.8	715.1	73.31	-724
October	264	13.9	431.6	44.24	-363.3
November	330	6.4	194.7	19.96	-153.8
December	373	7.1	222.9	22.85	-46.5
Total	4741	17.235	6297.546	645.5	-5210.5

Legend:

* Monthly consumption used from NB Power system.

** Average daily production throughout each month in kilowatt hours.

*** Total monthly production of the panels in kilowatt hours.

**** Savings in dollars the energy production would equate to using \$10.25 per kilowatt hour.

***** Credit Received by NB Power in kilowatt hours that they negate from the bill.

Lessons Learned

The first step before considering a renewable energy source is making sure the home or building is as energy efficient as possible. It is more cost effective to save energy through maximizing building efficiency than installing renewable energy sources. However, both help the environment and lower your power bill.

“We all use energy daily,” says Heather. “Getting started with meeting your own energy needs is exciting and empowering.”

If you choose to net meter, keep in mind that the process for installing a renewable energy system can be lengthy in order to ensure the equipment is installed correctly and has the right certifications.

Make sure to take the following steps:

- Ensure your contractors are properly licensed and have the necessary electrical permits and certification requirements;
- If installing solar panels, verify the location receives maximum sun exposure for consistent and adequate electricity generation. Harsh conditions should also be kept in mind;
- Hire a professional who is familiar with code requirements and who can ensure that the local inspection authorities are involved from the start;
- Once the system is installed and online, monitor it weekly or monthly to ensure it is working properly.

Customer Experience

One great benefit to being “grid tied” from the Smith’s perspective is that their solar panel system is sized for their average usage, rather than their peak. Additionally, the Smiths highlight: “We like knowing that 100% of the excess power we produce is used within our neighborhood. Aside from the money saved, it is satisfying to do what you can as an individual towards the reduction of greenhouse gas emissions.”

“Our experience with the net metering program has raised our awareness of our energy consumption and the potential to generate electricity through the seasons. NB Power and our installer (Fundy Solar) led us through the process.”

For More Information

NB Power’s net metering program partners with customers like the Smiths to facilitate small-scale, environmentally sustainable generation while still connected to ‘the grid.’ The net metering program deals with a mix of homes and business and small scale renewable generation technologies. You can find more case studies at www.nbpower.com/

Contact us at 1 800 663-6272 or at www.nb.power.com to learn more about net metering and energy conservation. We are happy to help our customers learn about this renewable energy option and will provide you with the up-to-date information you need to make the best decisions possible.